

Fabrication and Heat Treated Guidelines

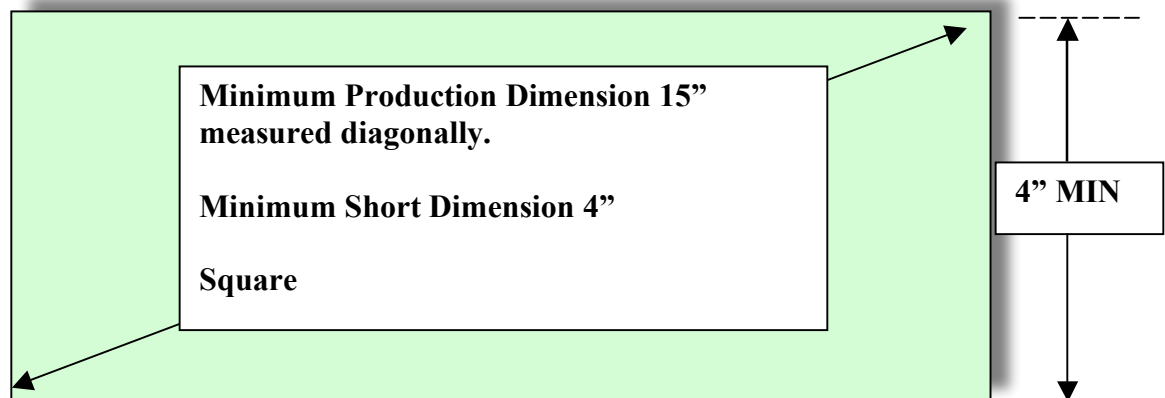

Fabrication and Heat Treated Guidelines

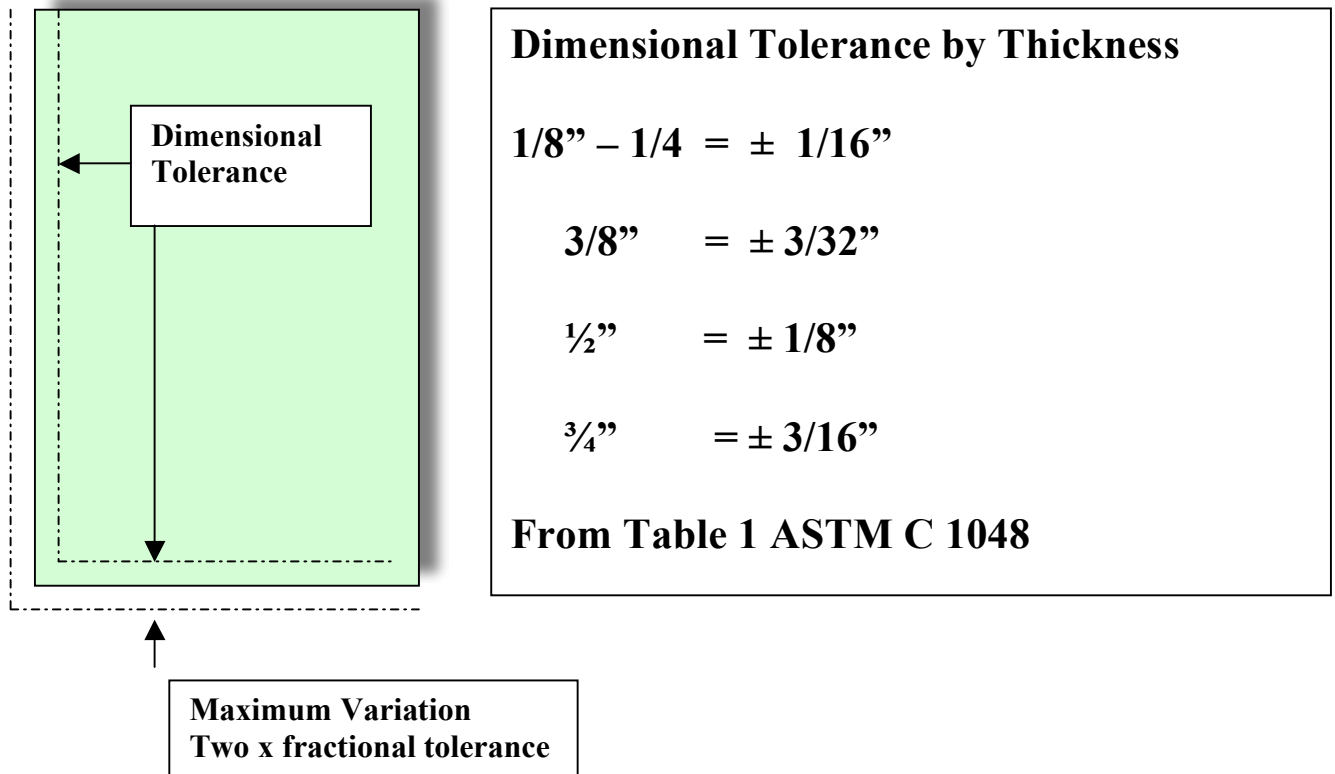
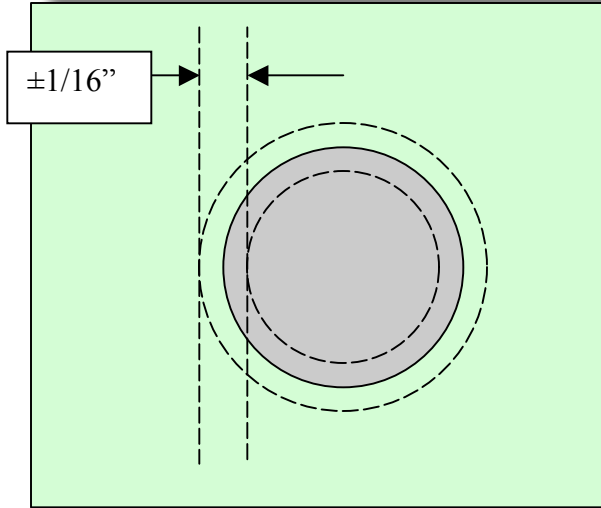

Minimum hole diameter must be $1/4''$ or the glass thickness, whichever is greater.

Maximum hole or cut out cannot exceed $1/3$ of smallest glass dimension.

Hole diameter tolerance $\pm 1/16''$

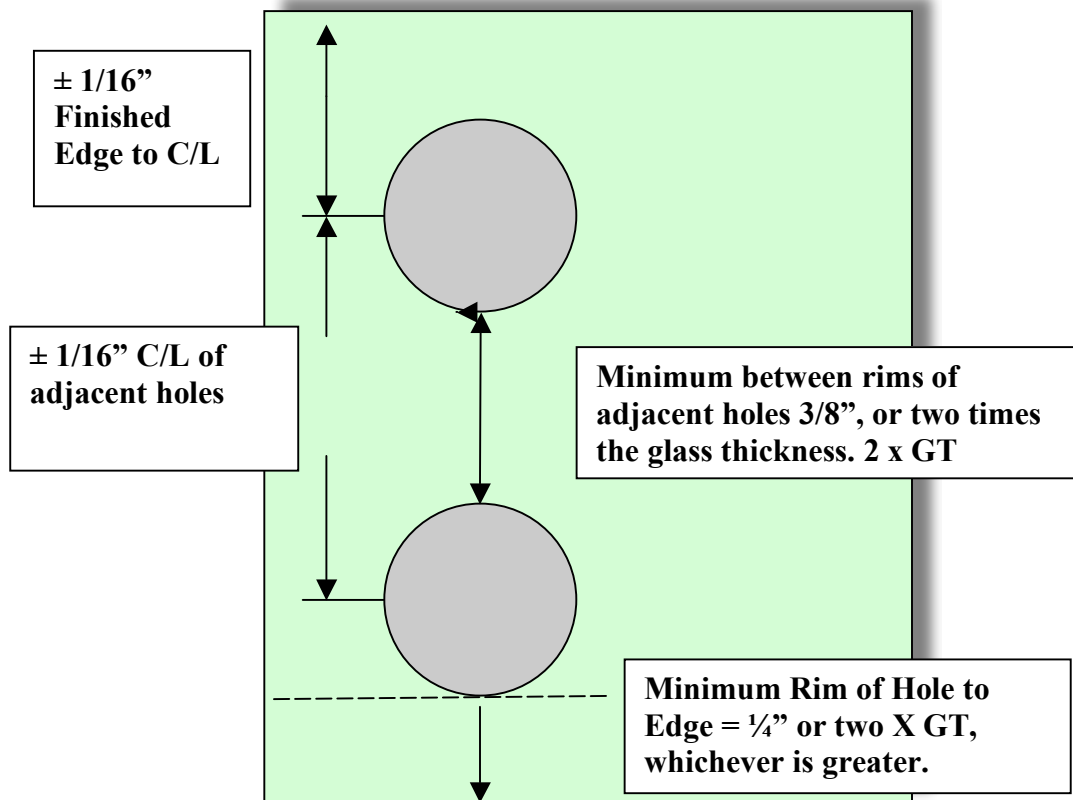

Hole Location Tolerance

Fabrication and Heat Treated Guidelines

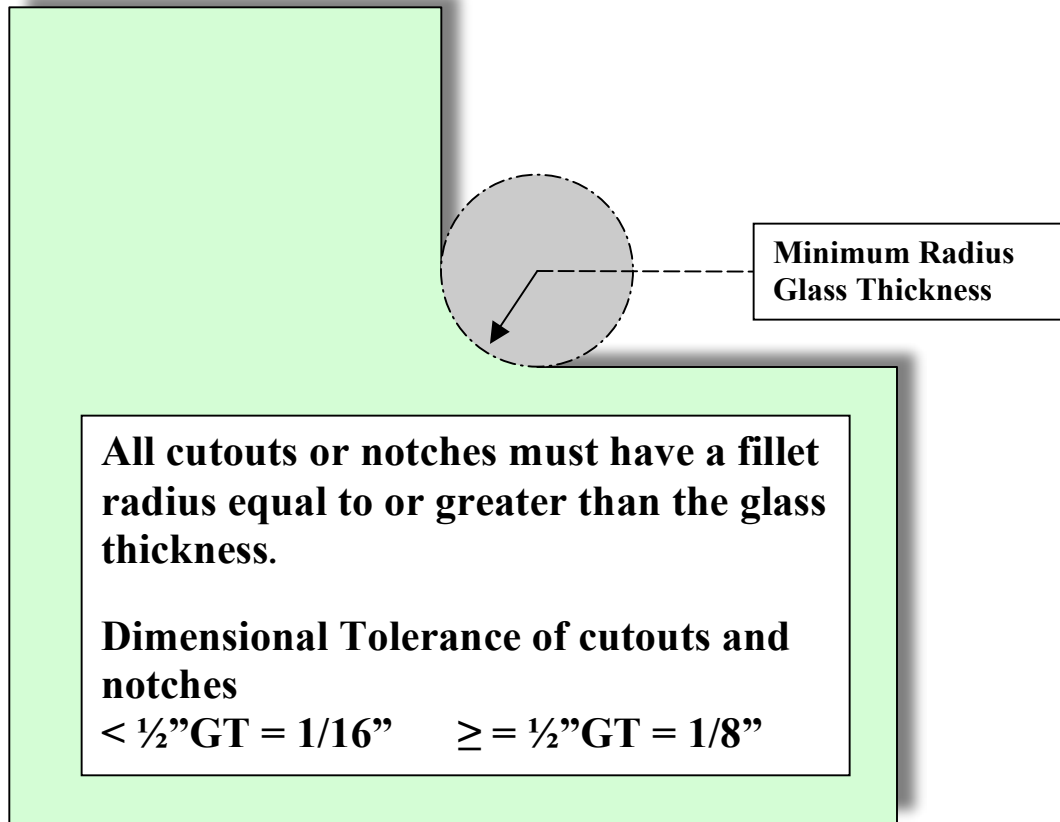

Fabrication and Heat Treated Guidelines

